

## FORESTRY MULCHERS

# UMM/S

### Mulcher for tractors from 180 to 350 hp.

High productivity, robustness and maneuverability are the main strengths of this mulcher with a fixed rotor system. The UMM/S is a very versatile model for tractors between 180 and 350 hp. It has a mulching capacity of up to 14 in diameter material. The well distributed weight allows for great maneuverability also in steep and sloppy

applications. The alignment PTO system "W" connected to the central gearbox, allows for a wider working angle of the PTO shaft in all working conditions. This new model features the new counter-blade Spike PRO as standard equipment.



180-350 hp



Ø 14 in max

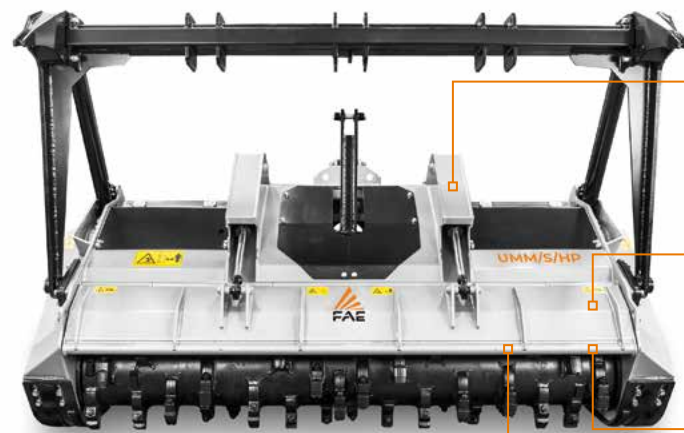

**Cylinder protection**  
to prevent cylinder damage

**Reinforced hydraulic hood**  
helps provide a finer product while being more durable



**Spike PRO counter-blade**  
the distribution of the new Spike PRO counter-blades inside the shredding chamber guarantees a better finish of the mulched material



**Inner anti wear clad plates FCP**  
absorbs wear while protecting the frame

**Z style self ranging system of the PTO drive shaft/gearbox**  
always keeps the correct operating angle between the PTO shaft and the power take-off

**Bigger transmission**  
for tractors with power up to 350 hp

**Adjustable extended 3 point linkage**  
fits perfectly with any kind of tractor



## MAIN OPTIONS



**W style self aligning device between PTO drive shaft/gearbox**  
allows the mulcher to work at several angles without damaging the PTO



**Mechanical/hydraulic push frame**  
guides and pushes material away from carrier



**Additional ripper for push frame**  
helps with the positioning of standing material while mulching



**Standard hydraulic clutch transmission**  
protects the transmission at PTO engagement for smooth starting and improves machine performance

## STANDARD EQUIPMENT

Hydraulic rear hood	Gearbox with freewheel
Adjustable extended 3 point linkage	PTO shaft with cam clutch
Supporting service leg	Bolted-on rotor shafts (in forged steel)
Centralized greasing hub	Hydraulic top link
Hydraulic hoses integrated in the frame	Z style self ranging system of the PTO drive shaft/gearbox
Cylinder protection	Interchangeable bolted on Spike PRO counter-blade
Dual row protection chains	Adjustable skids
Transmission with belts	

## OPTIONS

Bolt-on chain's protection plates	Special skids to go underground
Hydraulic clutch transmission (UMM/S, UMM/S/HP-225 et UMM/S/HP-250)	Mechanical guard frame
Multiple tooth options	Hydraulic guard frame
W style self aligning device between PTO drive shaft/gearbox	Extra ripper for guard frame
IVT - CVT or creeper transmission strongly recommended	Forestry tires and carrier belly pan strongly recommended

MODEL	UMM/S-200	UMM/S-225	UMM/S-250	UMM/S/HP-200	UMM/S/HP-225	UMM/S/HP-250
<b>Engine (hp)</b>	180-280	190-280	200-280	180-350	190-350	200-350
<b>PTO (rpm)</b>	1000	1000	1000	1000	1000	1000
<b>Working width (in)</b>	81	91	100	81	91	100
<b>Total width (in)</b>	98	108	117	98	108	117
<b>Weight including rotor</b> type C/3 (lbs)	6482	6768	7077	6570	7297	7606
type B/3 (lbs)	7165	7408	7760	7231	7893	8532
<b>Rotor diameter (in)</b>	23.4	23.4	23.4	23.4	23.4	23.4
<b>Max shredding diameter (in)</b>	14	14	14	14	14	14
<b>No. teeth</b> type B/3+C/3/SS	72+2	80+2	92+2	72+2	80+2	92+2
type C/3+C/3/SS	44+2	50+2	56+2	44+2	50+2	56+2

Data refers to machine as standard set-up. Options may have reflects on weights and dimensions. The technical data in this catalogue may be altered without prior notice.

## ROTOR TYPE B



**TOOTH B/3**  
(standard)



**TOOTH B/3/HD**  
(option)

## ROTOR TYPE C



**TOOTH C/3**  
(standard)



**TOOTH C/3/HD**  
(option)



**TOOTH K/3**  
(option)



**TOOTH C/3/SS**  
(side scraper)