

FORESTRY MULCHERS

UMM

Mulcher for tractors from 160 to 240 hp.

The UMM is a professional forestry mulcher with a fixed rotor system and a mulching capacity up to 12 in in diameter. This unit is ideal for heavy land clearing applications. The frame has been completely redesigned and it makes the mulcher more maneuverable when working on steep slopes and in extreme conditions.

This model features the new counterblade Spike PRO as standard equipment, and features the new hydrodynamic joints as an option. The UMM also features interchangeable antiwear plates in Hardox® steel, new centralized greasing system and guide frame with Ripper guide pins.



160-240 hp



Ø 12 in max

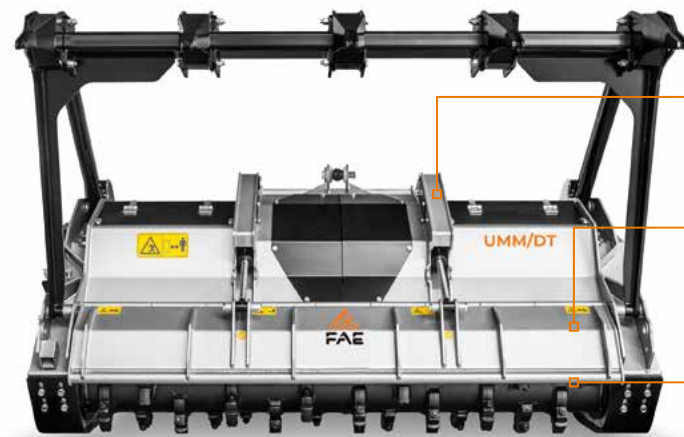

Cylinder protection
to prevent cylinder damage

Reinforced hydraulic hood
helps provide a finer product while being more durable

Forged and hardened interchangeable counter-blades
for the longest working life while providing a finer product



Z style self ranging system of the PTO drive shaft/gearbox
helps keep the correct operating angle between the PTO shaft and the power take-off



Centralized greasing hub
allows easy maintenance

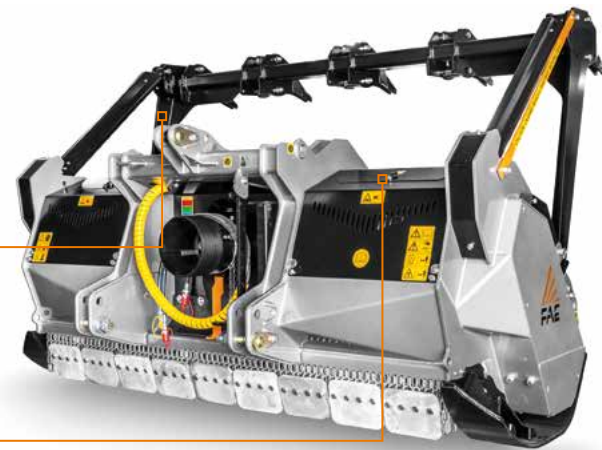

MAIN OPTIONS



W style self-aligning device between PTO drive shaft/gearbox
allows the mulcher to work at several angles without damaging the PTO



Standard hydraulic clutch transmission
protects the transmission at PTO engagement for smooth starting and improves machine performance

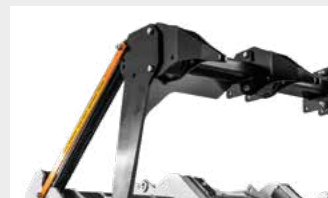

Mechanical/hydraulic push frame
guides and pushes material away from carrier



Additional ripper for push frame
helps with the positioning of standing material while mulching

STANDARD EQUIPMENT

Hydraulic rear hood	Gearbox with freewheel
Enclosed machine body	PTO shaft with cam clutch
Supporting service leg	Bolted-on rotor shafts (in forged steel)
Hydraulic hoses integrated in the frame	Hydraulic top link
PTO shaft support for machine at rest	Z style self ranging system of the PTO drive shaft/gearbox
Dual row protection chains	Interchangeable bolted on Spike PRO counter-blade
Transmission with belts	Adjustable skids

OPTIONS

Bolt-on chain's protection plates	Special skids to go underground
Hydraulic clutch transmission	Mechanical guard frame
Multiple tooth options	Hydraulic guard frame
W style self-aligning device between PTO drive shaft/gearbox	Extra ripper for guard frame
IVT - CVT or creeper transmission strongly recommended	Forestry tires and carrier belly pan strongly recommended

MODEL	UMM/DT-200	UMM/DT-225	UMM/DT-250
Engine (hp)	160-240	170-240	180-240
PTO (rpm)	1000	1000	1000
Working width (in)	81	91	100
Total width (in)	97	106	116
Weight (lbs)	5082	5357	5512
Rotor diameter (in)	19.7	19.7	19.7
Max shredding diameter (in)	12	12	12
No. teeth type C/3+C/3/SS	42+2	46+2	52+2
type I+C/3/SS	68+2	78+2	86+2

Data refers to machine as standard set-up. Options may have reflects on weights and dimensions. The technical data in this catalogue may be altered without prior notice.

ROTOR TYPE C



TOOTH C/3
(standard)



TOOTH C/3/HD
(option)



BLADE BL
(option - requires adaptor)



TOOTH K/3
(option)



TOOTH STCL/3
(optional)



TOOTH I
(option)



TOOTH C/3/SS
(side scraper)

ROTOR TYPE I