

# FORESTRY MULCHERS UMH/MEGA

Mulcher for tractors from 350 to 500 hp.

UMH/MEGA is a unique forestry mulcher. It is designed for the most powerful tractors available, and allows you to work large areas in a quick and effective way. The UMH/MEGA was built for operators seeking a highly

productive mulcher combined with an extremely efficient tiller. It can mulch trees up to 20 in diameter and grind at a depth of 10 in, all in one machine.



350-500 hp



Ø 20 in max



Depth 10 in

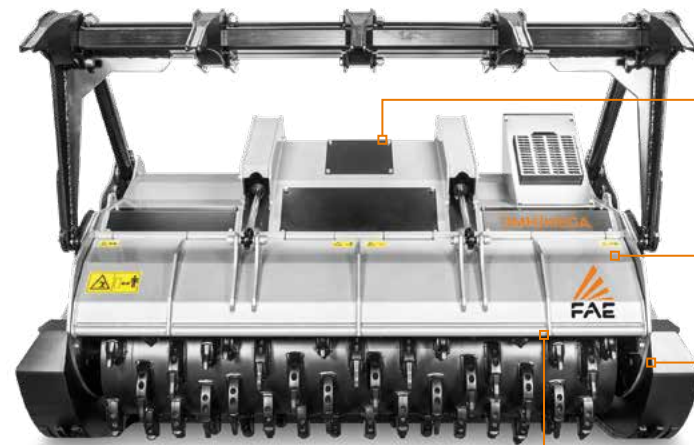

**Z style self-ranging system for the PTO drive shaft/gearbox** helps keep the correct operating angle between the PTO shaft and the power take-off

**Three rows of forged and hardened interchangeable counter-blades** for the longest working life while providing a finer product



**Aggressive body design** the protruding rotor allows more material to process without dragging

**Inner anti wear clad plates FCP** absorbs wear while protecting the frame



**Standard hydraulic clutch transmission** protects the transmission at PTO engagement for smooth starting and improves machine performance



**Adjustable extended 3 point hitch** fits perfectly with any type of tractor

**Side transmission with belts in Poly-Chain® Carbon** for longer lasting performance

## MAIN OPTIONS



**Hydraulically adjustable skids** allow the rotor to penetrate deeply into the soil for grinding stumps and roots



**W style self-aligning device between PTO drive shaft/gearbox** allows the mulcher to work at several angles without damaging the PTO



**Hydraulic push frame** guides and pushes material away from carrier



**Additional ripper for push frame** helps with the positioning of standing material while mulching

## STANDARD EQUIPMENT

Hydraulic rear hood	Hydraulic clutch transmission
Inner anti wear clad plates FCP	Gearbox with freewheel
Adjustable extended 3 point linkage	Gearbox with oil cooling system
Enclosed machine body	PTO shaft
Centralized greasing hub	Bolted-on rotor shafts (in forged steel)
Hydraulic hoses integrated in the frame	Hydraulic top link
Cylinder protection	Z style self ranging system of the PTO drive shaft/gearbox
Inside lateral protection	Forged and hardened interchangeable counter-blades
Dual row protection chains	Third row of interchangeable forged and hardened counter-blades
Poly-Chain® belts transmission	

## OPTIONS

Multiple tooth options	Special skids to go underground
W style self-aligning device between PTO drive shaft/gearbox	Hydraulic guard frame
Hydraulically adjustable skids	Extra ripper for push frame
IVT - CVT or creeper transmission strongly recommended	Forestry tires and carrier belly pan strongly recommended

MODEL	UMH/MEGA-225	UMH/MEGA-250
<b>Engine (hp)</b>	350-500	350-500
<b>PTO (rpm)</b>	1000	1000
<b>Working width (in)</b>	91	101
<b>Total width (in)</b>	111	120
<b>Weight (lbs)</b>	13162	13933
<b>Rotor diameter (in)</b>	35.8	35.8
<b>Max shredding diameter (in)</b>	20	20
<b>Max working depth (in)</b>	10	10
<b>No. teeth type A/3+MH/3+BAZ</b>	94+2 +4	106+2+4

Data refers to machine as standard set-up. Options may have reflects on weights and dimensions. The technical data in this catalogue may be altered without prior notice.

## ROTOR TYPE A



**TOOTH A/3**  
(standard)



**TOOTH A/3/HD**  
(option)



**TOOTH MH/3**  
(side scraper)



**TOOTH BAZ**  
(side scraper)