

MULTITASKS

MTL

Multitask head for tractors from 140 to 300 hp.

The MTL enables soil stabilization, asphalt and rock slab shredding, and stone crushing, down to a maximum operating depth of 11 inches. The variable-geometry grinding chamber, adjustable grille on the hood, and adjustable Hardox counter blade consistently enable optimal crushing results. Internal protection plates on the frame, bolted both centrally and laterally, ensure the head is robust and reliable while also guaranteeing

excellent resistance to wear. The handy depth indicator allows you to check the operating level directly from the cab, and the central gearbox with universal-joint alignment system is designed to be compatible with a wide range of tractors on the market. The head comes standard with G/3 teeth, with the option of G/3/HD teeth and R/65 or R/65/HD picks on a dedicated rotor.



140-300 hp



Depth 11 in max



Variable displacement chamber

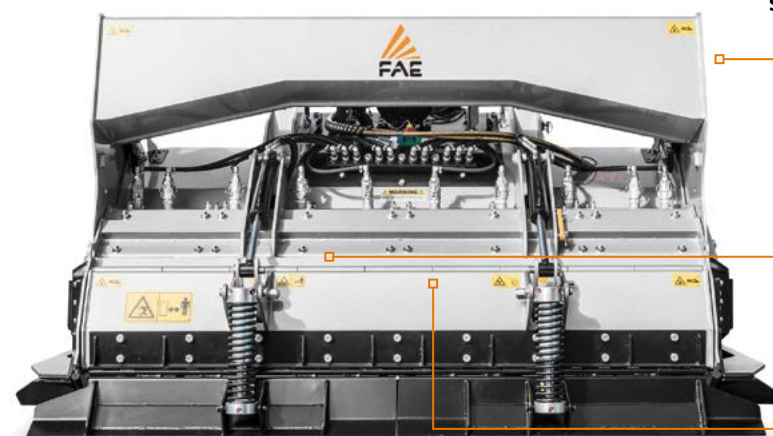

Side wear plates on the inner sides of the frame highly resistant to wear and tear, equalling less down time due to replacement

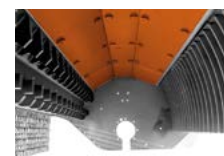

Rear access panel

Hardox® steel - Wear plates these allow the machine to resist wear and tear and can be easily replaced as needed



Rear grid
the grid on the rear door helps define the size of the output materials

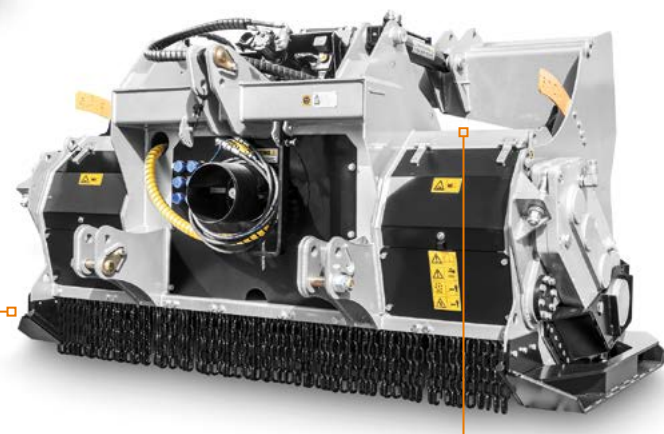

Variable displacement chamber
this technological solution, which is one of a kind in the industry, allows the ground to be penetrated with the rotor alone

MAIN OPTIONS



Hydraulic top link



Multiple tooth options



The **Water Spray System** (Basic & High Flow) has the dual function of cooling and mixing

STANDARD EQUIPMENT

Hydraulically adjustable rear hood	Transmission with side gearbox
Interchangeable wear-resistant Hardox® plates	Freewheel gearbox
Enclosed, dust-resistant machine body	Side PTO shafts with friction clutches
Variable displacement chamber	Central PTO shaft with cam clutch
Adjustable hood grille	Interchangeable forged steel rotor shafts
Wear-resistant side plates	Adjustable Hardox® counter blade
Bolt-on interchangeable protection chains	Dozing blades with spring system
FCP wear-resistant clad plates	PTO shaft support for machine at rest

OPTIONS

Multiple tooth options	Basic WSS - water spray system
Hydraulic top link cylinder	High Flow WSS - water spray system

IVT - CVT or creeper transmission mandatory

MODEL	MTL-150	MTL-175	MTL-200	MTL-225	MTL-250
Engine (hp)	140-240	150-240	160-300	170-300	180-300
PTO (rpm)	1000	1000	1000	1000	1000
Working width (in)	58	68	77	87	96
Total width (in)	72	81	91	100	109
Weight (lbs)	7430	7981	8532	9083	9634
Rotor diameter (in)	23.4	23.4	23.4	23.4	23.4
G/3 Working depth (in) (Max. 1-Max. 2)	6-11	6-11	6-11	6-11	6-11
No. teeth type G/3+STC/3/FP	42+6	50+6	60+6	70+6	78+6
Rotor diameter (in)	24	24	24	24	24.1
ROTOR R (optional) Working depth (in) (Max. 1-Max. 2)	6-11	6-11	6-11	6-11	6-11
No. picks type R/65+R/65/HD	98+16	114+16	138+16	154+16	170+16

Max. 1: with rotor only Max. 2: maximum depth (maximum working depth depending on ground conditions).
This information refers to the machine equipped as standard. The technical data in this catalogue may be altered without prior notice.

ROTOR TYPE G



TOOTH G/3 (standard)



TOOTH G/3/HD (option)



ADAPTOR G/3 WITH PICK R/44 (option)



TOOTH STC/3/FP (side scraper)

ROTOR TYPE R



PICK R/65 (standard)



PICK R/65/HD (option)



ADAPTOR R/65 WITH PICK R/44 (option)



PICK R/65/HD (side scraper)