

BLADE FOR SPECIAL VEHICLES

Dozer Blade

Eight-way dozer blade with heavy-duty structure and 94.5 in width. Designed for rough and finish grading in dirt and leveling, the FAE Dozer blade features interchangeable Hardox® wear-resistant cutting edges, a guarantee of resistance and reliability. Thanks to the hydraulic control of the movements, the blade can reach 15° of angle and 10° of side-tilt in both directions. The hydraulic system is equipped with relief valves to protect it from overload in the angle and side-tilt movements.



MOVEMENTS RANGE



1. Side-tilt

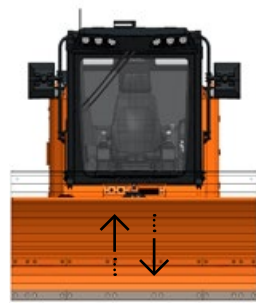

2. Lift

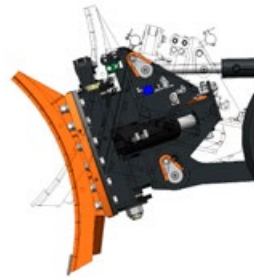

3. Front-tilt

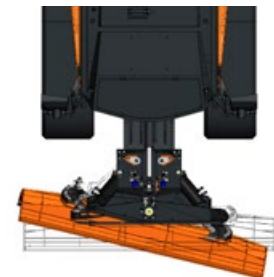

4. Angle

The 8-way movement allows side-tilting (1), lifting/lowering (2), front-tilting (3) and angle (4) the blade, all from the vehicle cabin.

TECHNICAL SPECIFICATIONS

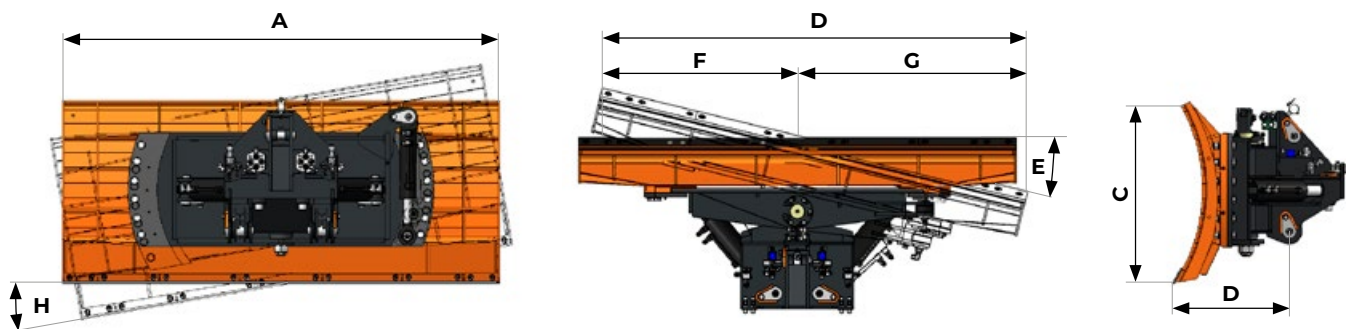

MODEL

Dozer Blade

A. Blade width (in)	95
B. Width fully angled (in)	91
C. Moldboard height (in)	38
D. Overall length with attachment plate (in)	25
E. Blade angle	±15°
F. Center blade-left edge distance (when fully angled) (in)	42
G. Center blade-right edge distance (when fully angled) (in)	50
H. Blade side-tilt	±10°
Weight (lbs)	2954
Moldboard thickness (in)	0,6

Data refers to machine as standard. The technical data in this catalogue may be altered without prior notice.