

## BLADE FOR SPECIAL VEHICLES

# Dozer Blade

Eight-way dozer blade with heavy-duty frame and 94.5 in working width. Designed for rough and finish grading in dirt, leveling and trenching. Hydraulic controlled angle and tilt. Angles 15° right or left off center. Tilts 10 degrees off horizontal both directions. Relief valves to protect the hydraulic angling system when the blade is overloaded.



### RANGE OF MOTION



1. Tilt

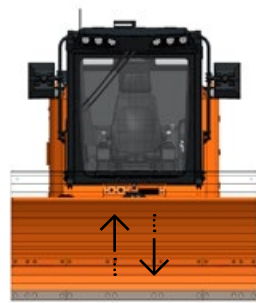

2. Lift

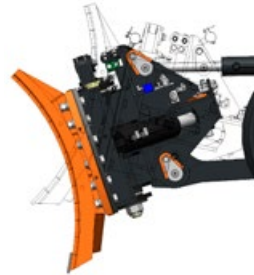

3. Roll

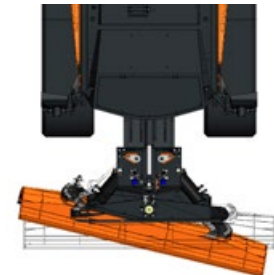

4. Angle

The 8-way movement allows you to tilt (1), lift (2), roll (3) and angle (4) the blade, all from the cab or remote control of your PT-175!

### TECHNICAL SPECIFICATIONS

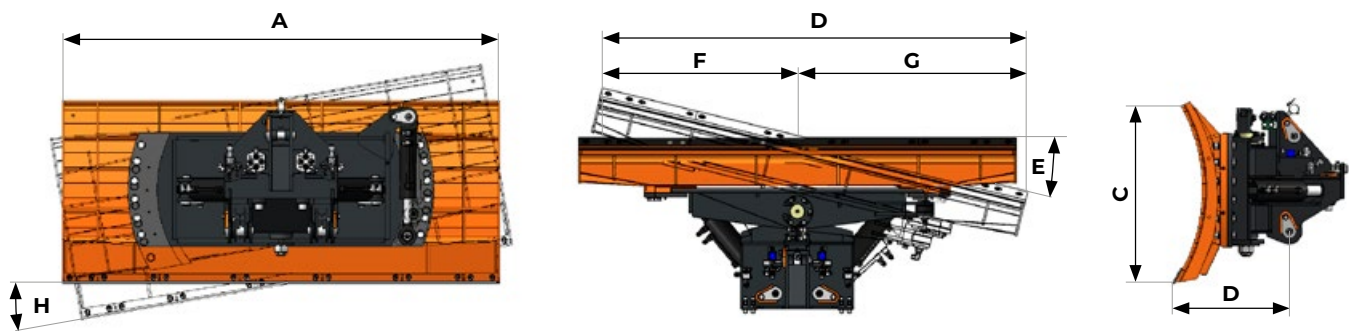

#### MODEL

#### Dozer Blade

<b>A. Blade width (in)</b>	95
<b>B. Working width (in)</b>	91
<b>C. Moldboard height (in)</b>	38
<b>D. Overall depth with attachment plate (in)</b>	25
<b>E. Blade angle</b>	±15°
<b>F. Center line to edge, when angled (in)</b>	42
<b>G. Center line to edge (in)</b>	50
<b>H. Blade tilt</b>	±10°
<b>Weight (lbs)</b>	2954
<b>Moldboard thickness (in)</b>	0,6

Data refers to machine as standard. The technical data in this catalogue may be altered without prior notice.