

FORESTRY MULCHERS

UMH/S

Mulcher for tractors from 240 to 500 hp.

The UMH/S is FAE's top of the line tractor mounted forestry mulcher. It is rated for trees up to 45 cm diameter and is designed to work with high horsepower tractors. The hydrodynamic joints and the Spike PRO counter-blades guarantee optimal performance and productivity. The ergonomics of the new, fully enclosed double layer "dustproof" frame is designed for maximum safety of the work and the operator. Finally, the large diameter of the rotor and the new Spike PRO counter-blades provide excellent homogenous shredding results. Backed by FAE's unparalleled engineering expertise, UMH/S/HP is built to last and delivers the maximum return on your investment.

frame is designed for maximum safety of the work and the operator. Finally, the large diameter of the rotor and the new Spike PRO counter-blades provide excellent homogenous shredding results. Backed by FAE's unparalleled engineering expertise, UMH/S/HP is built to last and delivers the maximum return on your investment.



240-500 hp



Ø 45 cm max

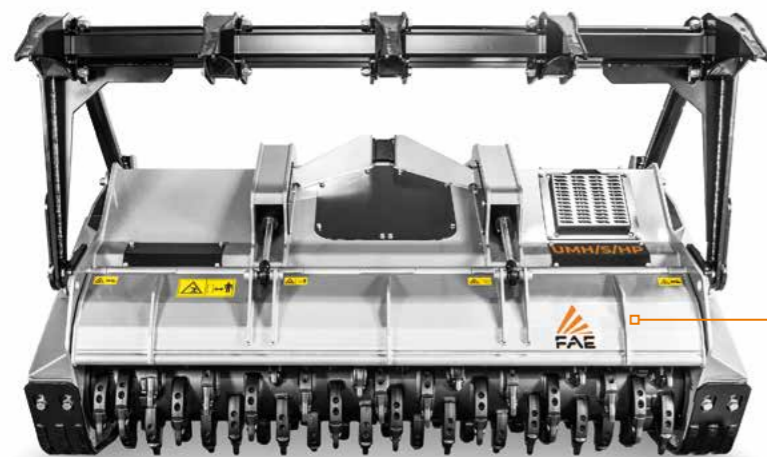

Spike Control Pro and their distribution produce a finer shredding result



Centralized greasing hub for easier maintenance



Adjustable extended 3 point hitch fits perfectly with any kind of tractor

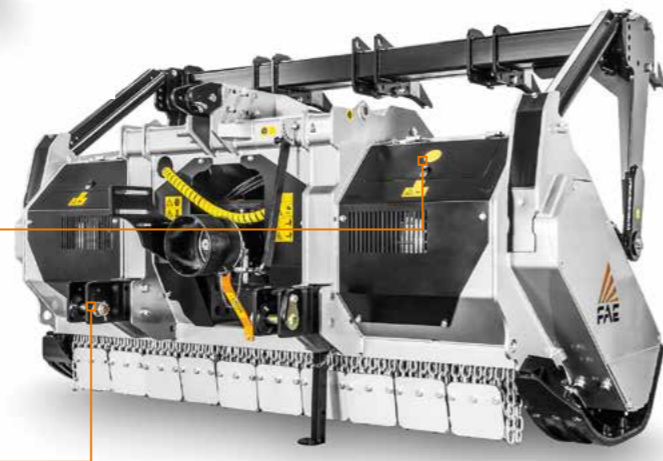

MAIN OPTIONS



W style self-aligning device between PTO drive shaft/gearbox allows the mulcher to work at several angles without damaging the PTO



Hydraulic push frame guides and pushes material away from carrier



Additional ripper for push frame helps with the positioning of standing material while mulching



Standard hydraulic clutch transmission protects the transmission at PTO engagement for smooth starting and improves machine performance

STANDARD EQUIPMENT

| | |
|---|--|
| Hydraulic rear hood | Gearbox with oil cooling system (UMH/S/HP) |
| Wear-resistant side plates | PTO shaft |
| Adjustable extended 3 point linkage | Side PTO shafts with cam clutches |
| Hydraulic top link | Hydraulic clutch transmission (UMH/S/HP) |
| Interchangeable forged steel rotor shafts | Z style self ranging system of the PTO drive shaft/gearbox |
| PTO shaft support for machine at rest | Gearbox with freewheel |
| Bolted on protection chains | Interchangeable bolted on Spike PRO counter-blade |
| Trapezoidal belts transmission (UMH/S) | Adjustable skids |
| Poly-Chain® belts transmission (UMH/S/HP) | Supporting service leg |

OPTIONS

| | |
|--|---------------------------------|
| Bolt-on chain's protection plates | Special skids to go underground |
| Hydraulic clutch transmission (UMH/S) | Hydraulic guard frame |
| Multiple tooth options | Extra ripper for guard frame |
| W style self-aligning device between PTO drive shaft/gearbox | |

| MODEL | UMH/S-225 | UMH/S-250 | UMH/S/HP-225 | UMH/S/HP-250 |
|---|-----------|-----------|--------------|--------------|
| Tractor (hp) | 240-400 | 250-400 | 350-500 | 350-500 |
| PTO (rpm) | 1000 | 1000 | 1000 | 1000 |
| Working width (mm) | 2320 | 2560 | 2320 | 2560 |
| Total width (mm) | 2760 | 3000 | 2760 | 3000 |
| Weight including rotor type C/3 (kg) | 4200 | 4440 | 5100 | 5200 |
| type A/3 (kg) | 4510 | 4660 | 5400 | 5500 |
| Rotor diameter (mm) | 680 | 680 | 680 | 680 |
| Max shredding diameter (mm) | 400 | 400 | 450 | 450 |
| No. teeth type A/3+MH/3 | 88+2 | 96+2 | 88+2 | 96+2 |
| type C/3+C/3/SS | 54+2 | 60+2 | 54+2 | 60+2 |

Data refers to machine as standard. The technical data in this catalogue may be altered without prior notice.

ROTOR TYPE A



TOOTH A/3 (standard)



TOOTH A/3/HD (option)



TOOTH MH/3 (side scraper)

ROTOR TYPE C



TOOTH C/3 (standard)



TOOTH C/3/HD (option)



TOOTH K/3 (option)



TOOTH C/3/SS (side scraper)