

FORESTRY MULCHERS

UMH/MEGA

Mulcher for tractors from 350 to 500 hp.

UMH/MEGA is a unique forestry mulcher. It is designed for the most powerful tractors available, and allows you to work large areas in a quick and effective way. The UMH/MEGA was built for operators seeking a

highly productive mulcher combined with an extremely efficient tiller. It can mulch trees up to 50 cm diameter and grind at a depth of 25 cm, all in one machine.



350-500 hp

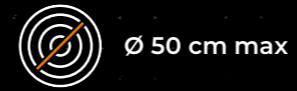

Ø 50 cm max



Depth 25 cm

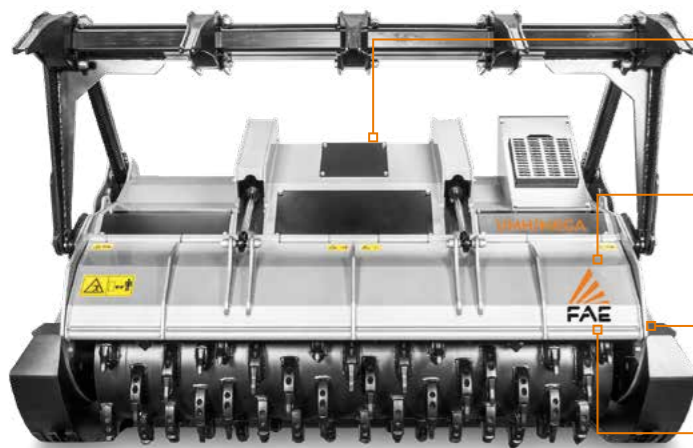

Three rows of forged and hardened interchangeable counter-blades for the longest working life while providing a finer product



Z style self-ranging system for the PTO drive shaft/gearbox helps keep the correct operating angle between the PTO shaft and the power take-off

Aggressive body design the protruding rotor allows more material to process without dragging

Inner anti wear clad plates FCP absorbs wear while protecting the frame



Standard hydraulic clutch transmission protects the transmission at PTO engagement for smooth starting and improves machine performance



Adjustable extended 3 point hitch fits perfectly with any type of tractor

Side transmission with belts in Poly-Chain® Carbon for longer lasting performance

MAIN OPTIONS



Hydraulically adjustable skids allow the rotor to penetrate deeply into the soil for grinding stumps and roots



W style self-aligning device between PTO drive shaft/gearbox allows the mulcher to work at several angles without damaging the PTO



Hydraulic push frame guides and pushes material away from carrier



Additional ripper for push frame helps with the positioning of standing material while mulching

STANDARD EQUIPMENT

| | |
|---|---|
| Hydraulic rear hood | Hydraulic clutch transmission |
| Inner anti wear clad plates FCP | Gearbox with freewheel |
| Adjustable extended 3 point linkage | Gearbox with oil cooling system |
| Enclosed machine body | PTO shaft |
| Centralized greasing hub | Bolted-on rotor shafts (in forged steel) |
| Hydraulic hoses integrated in the frame | Hydraulic top link |
| Cylinder protection | Z style self ranging system of the PTO drive shaft/gearbox |
| Inside lateral protection | Forged and hardened interchangeable counter-blades |
| Dual row protection chains | Third row of interchangeable forged and hardened counter-blades |
| Poly-Chain® belts transmission | |

OPTIONS

| | |
|--|---------------------------------|
| Multiple tooth options | Special skids to go underground |
| W style self-aligning device between PTO drive shaft/gearbox | Hydraulic guard frame |
| Hydraulically adjustable skids | Extra ripper for push frame |

| MODEL | UMH/MEGA-225 | UMH/MEGA-250 |
|------------------------------------|--------------|--------------|
| Tractor (hp) | 350-500 | 350-500 |
| PTO (rpm) | 1000 | 1000 |
| Working width (mm) | 2320 | 2560 |
| Total width (mm) | 2820 | 3060 |
| Weight (kg) | 5970 | 6320 |
| Rotor diameter (mm) | 910 | 910 |
| Max shredding diameter (mm) | 500 | 500 |
| Max working depth (mm) | 250 | 250 |
| No. teeth type A/3+MH/3+BAZ | 94+2+4 | 106+2+4 |

ROTOR TYPE A



TOOTH A/3
(standard)



TOOTH A/3/HD
(option)



TOOTH MH/3
(side scraper)



TOOTH BAZ
(side scraper)