

## STUMP CUTTERS FOR SKID STEERS

# SCL/SSL

### Stump cutters for 75-120 hp skid steers.

The SCL/SSL works with 75-120 hp skid steers. This head can shred large stumps and roots up to 50 cm deep. Lateral oscillation with proportional hydraulic control makes it possible to work on a large area

without moving the vehicle. The SCL/SSL's Direct Drive motor minimizes maintenance and makes it possible to have an extremely compact machine body.



75-120 hp



50 cm max



Ø 40 cm max

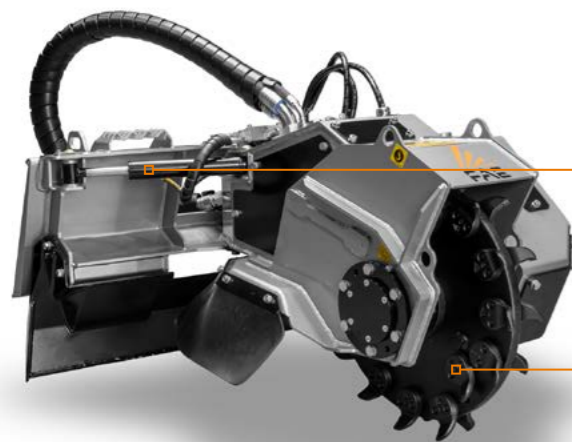

Proportional hydraulic control  
of the lateral oscillation

Disc rotor



Support blade  
for added stability while in operation (option)

#### STANDARD EQUIPMENT

125 cc hydraulic piston motor	Direct-drive transmission
Hydraulic block with safety and anticavitation valves	Hydraulic and proportional swing control
12 V diverter valve	Enclosed, dust-resistant machine body
Hydraulic hoses	Supporting leg
Interchangeable forged steel rotor shafts	Motor enclosed in the frame

#### OPTIONS

Adaptor wiring	Support blade
----------------	---------------

#### MODEL

	SCL/SSL
Engine (hp)	75-120
Flow rate (L/min)	120-150
Pressure (bar)	180-350
Working width max (mm)	950
Total width (mm)	1165
Weight (kg)	450
Max shredding diameter (mm)	400
Disc rotor diameter (mm)	660
Disc rotor width (mm)	112
Max working depth (mm)	500
No. teeth type L/1+L/2	15+15

Data refers to machine as standard. The technical data in this catalogue may be altered without prior notice.

#### MAIN OPTIONS



Wiring adaptors  
Wiring adaptors interface to allow a Plug & Play coupling with the most popular skid steers

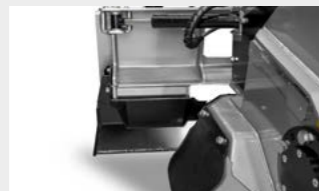

Support blade

#### DISC ROTOR



TOOTH L/1  
(standard)



TOOTH L/2  
(standard)