

FORESTRY MULCHERS FOR SPECIAL VEHICLES

140/U/PM

Heavy duty hydraulic mulcher for higher horse power carriers.

The 140/U/PM is the smallest model in the product line. Its small size makes it ideal for clearing corridors in the woods for seismic surveys and oil exploration. The sturdy frame means it can be used with tracked vehicles.



150-220 hp



Ø 25 cm max

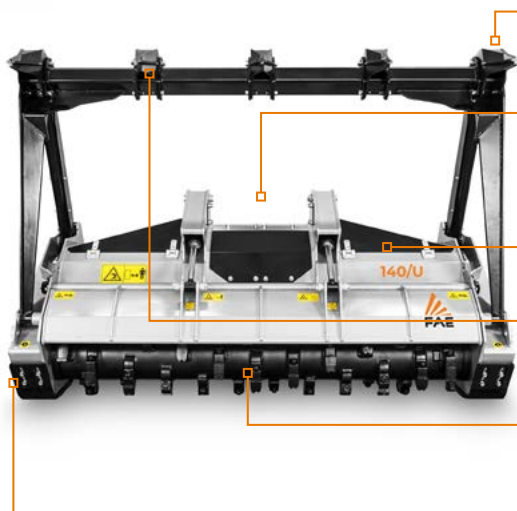

Mechanical or hydraulic push frame

Customized attachment plates

Hydraulically controlled hood to adjust final product size

Ripper teeth for push frame

Possibility to have optional rotor and tooth

Adjustable skids

STANDARD EQUIPMENT

Considering the various available options and high level of customization, the final configuration will be specified upon request.

MODEL	140/U/PM-140	140/U/PM-150	140/U/PM-175	140/U/PM-200	140/U/PM-225
Engine (hp)	150-220	150-220	150-220	150-220	150-220
Flow rate (L/min)	130-210	130-210	130-210	130-210	130-210
Pressure (bar)	250-400	250-400	250-400	250-400	250-400
Working width (mm)	1407	1587	1827	2067	2307
Total width (mm)	1751	1931	2171	2411	2651
Weight (kg)	1560	1600	1700	1800	1900
Rotor diameter (mm)	450	450	450	450	450
Max shredding diameter (mm)	250	250	250	250	250
No. teeth type C/3+C/3/SS	28+4	32+4	38+4	42+2	48+2

Data refers to machine as standard. The technical data in this catalogue may be altered without prior notice.

ROTOR TYPE C



TOOTH C/3
(standard)



TOOTH C/3/HD
(option)



BLADE BL
(option)



TOOTH STCL/3
(option)



TOOTH K/3
(option)

ROTOR TYPE BL



BLADE BL
(option)

ROTOR TYPE I



TOOTH I
(option)



TOOTH C/3/SS
(side scraper)