

FORESTRY TILLERS

SSH

Tiller for tractors from 160 to 500 hp.

SSH forestry tillers for 160 to 500 hp tractors ensure superior performance and reliability. The large rotor makes it possible to shred stumps up to 70 cm in diameter, and more teeth shred better than ever, even for roots up to 50 cm deep.

The combination of quality materials and technology - such as the counter blade and the interchangeable internal wear plates - provides unmatched productivity and reliability. The SSH/HP model also comes with a gearbox cooling system.

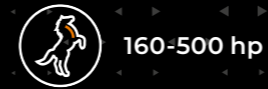

160-500 hp

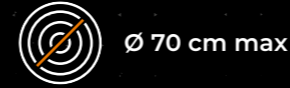

Ø 70 cm max



Depth 50 cm

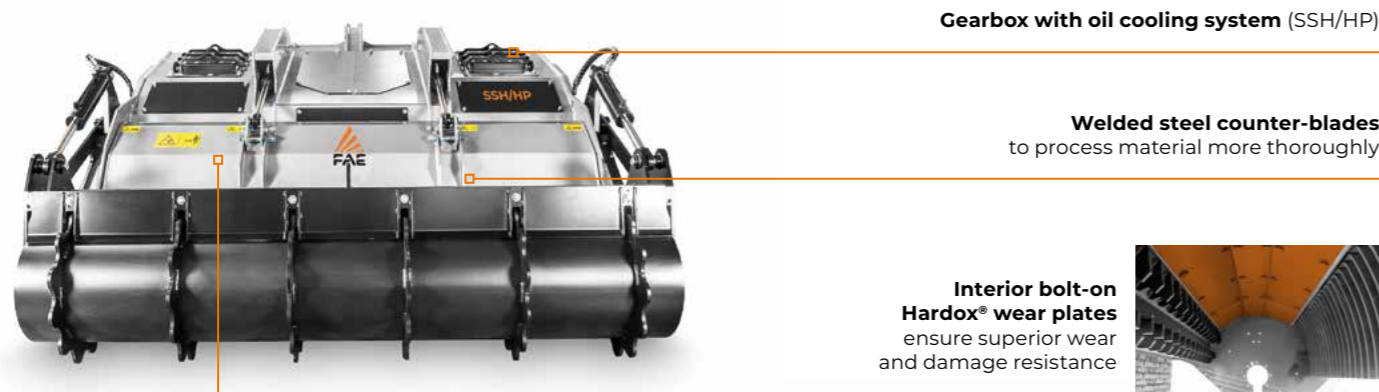

Gearbox with oil cooling system (SSH/HP)

Welded steel counter-blades
to process material more thoroughly

Interior bolt-on Hardox® wear plates
ensure superior wear and damage resistance



W style self aligning device between PTO drive shaft/gearbox
allows the mulcher to work at several angles without damaging the PTO



Centralized greasing hub
allows easy maintenance



Dual transmission with side gearbox
increase power delivery to the rotor

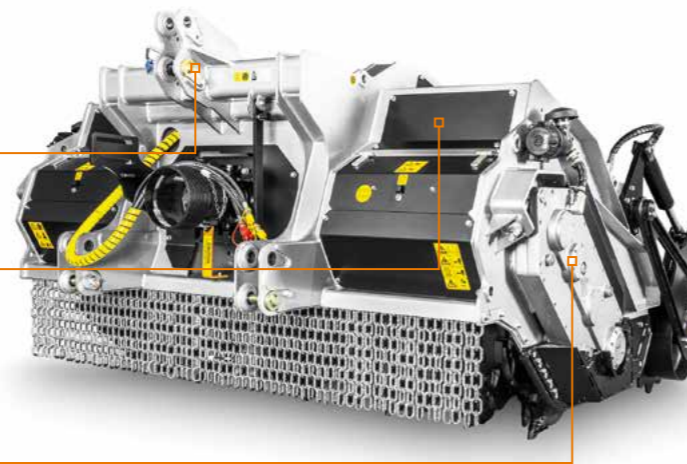

MAIN OPTIONS



Adjustable counter-blade (forest)
for additional processing of wood material



Hydraulic support roller or Wide hydraulic roller
produces fine-quality compacted soil faster



Independent Grid
for control of finer product; increased distance between the grid and the rear door allows a better material flow

STANDARD EQUIPMENT

Hydraulic rear hood	PTO shaft (SSH/HP)
Interchangeable inner antiwear plates in Hardox®	Friction clutches
Enclosed machine body	PTO shaft with cam clutch (SSH)
Inside lateral protection	Bolted-on rotor shafts (in forged steel)
Protection chains	Hydraulic top link
Transmission with side gearbox	Z style self ranging system of the PTO drive shaft/gearbox
Side gearbox with oil cooling system (SSH/HP)	Adjustable Hardox® counter-blade
Gearbox with freewheel	Special skids to go underground
Gearbox with oil cooling system (SSH/HP)	Centralized greasing hub

OPTIONS

Stronger transmission for tractors up to 360-400 hp (SSH-200, SSH-225, SSH-250)	Skids extension SSH-200, SSH-225, SSH-250, SSH/HP)
Multiple tooth options	Dozing blade
W style self aligning device between PTO drive shaft/gearbox	Hydraulic support roller
Adjustable counter-blade (forest)	Increased hydraulic roller

MODEL	SSH-150	SSH-175	SSH-200	SSH-225	SSH-250	SSH/HP-225	SSH/HP-250
Tractor (hp)	160-280	180-280	200-360 (400*)	220-360 (400*)	240-360 (400*)	360-500	360-500
PTO (rpm)	1000	1000	1000	1000	1000	1000	1000
Working width (mm)	1600	1840	2080	2320	2560	2320	2560
Total width (mm)	1980	2220	2472	2712	2952	2712	2952
Weight (kg)	3690	3920	4850	5200	5640	5310	5680
Rotor diameter (mm)	900	900	900	900	900	900	900
Max shredding diameter (mm)	700	700	700	700	700	700	700
Max working depth (mm)	500	500	500	500	500	500	500
No. teeth type A/3+MH/3	58+4	66+4	78+4	88+4	98+4	88+4	98+4

Data refers to machine as standard. The technical data in this catalogue may be altered without prior notice.

*Stronger trasmission.

ROTOR TYPE A



TOOTH A/3
(standard)



TOOTH A/3/HD
(option)



TOOTH F/3
(option)



TOOTH MH/3
(side scraper)