

MULTITASKS

SFL

Multitask for tractors from 130 to 220 hp.

Multitask head for 130 to 220 hp tractors. The SFL can shred wood, shrubs, roots up to 15 cm in diameter, stumps up to 25 cm in diameter and crush stones up to 10 cm in diameter, operating at depths down to 20 cm. Top features include the adjustable counter blade, the anti-wear Hardox

plates, the hydraulic hood, and the hydraulic support roller (optional). The SFL is available in two widths: SFL-200 and SFL-225, both with dual gear transmission. The head mounts a rotor with K/3 teeth.



130-220 hp



Ø 10 cm max (stones)
Ø 15 cm max (trees)
Ø 25 cm max (stump)



Depth 20 cm

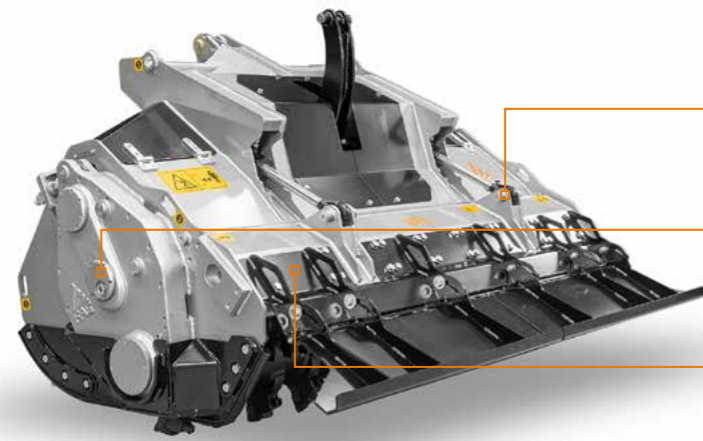

Hydraulically adjustable rear hood

Transmission with side gearbox
maximize the power delivered to the rotor

Interchangeable bolt-on counter blades
for fine mulching and easy maintenance

Bolt-on interchangeable protection chains

Adjustable Hardox® counter blade
to effectively control the final product size

Interchangeable wear-resistant Hardox® plates
for use in extreme conditions and for easier maintenance

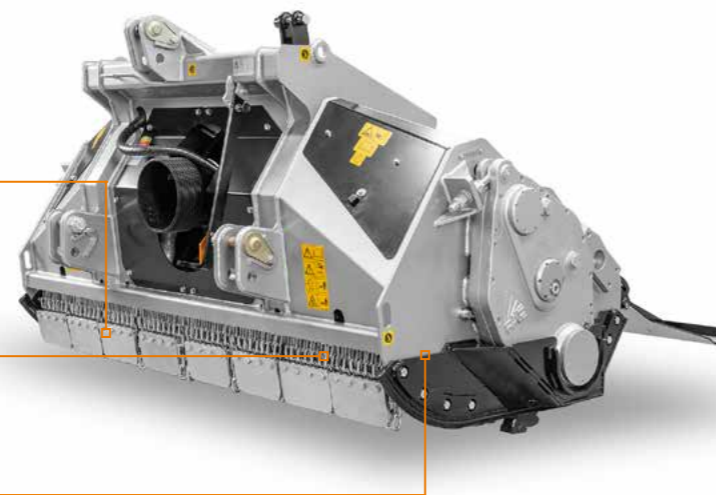

MAIN OPTIONS



Hood grille



Hydraulic support roller



Z style self-aligning system



W style self-aligning system

STANDARD EQUIPMENT

Hydraulically adjustable rear hood	Central PTO shaft with cam clutch
Interchangeable wear-resistant Hardox® plates	Interchangeable forged steel rotor shafts
Wear-resistant side plates	Interchangeable bolt-on counter blades
Bolt-on interchangeable protection chains	Adjustable Hardox® counter blade
Transmission with side gearbox	Skids to go underground
Freewheel gearbox	PTO shaft support for machine at rest
Side PTO shafts with friction clutches	Rotor with teeth K/3

OPTIONS

Hood grille	Z style self-aligning system
Plates for bolt-on protection chains	W style self-aligning system
Hydraulic support roller	Dozing blades
Hydraulic top link cylinder	

MODEL	SFL-200	SFL-225
Tractor (hp)	130-220	130-220
PTO (rpm)	1000	1000
Working width (mm)	2080	2320
Total width (mm)	2406	2646
Weight (kg)	2450	2600
Rotor diameter (mm)	555	555
Max shredding diameter		
Stones (mm)	100	100
Trees (mm)	150	150
Stump (mm)	250	250
Max working depth (mm)	200	200
No. teeth type K/3+C/3/SS+BAZ	52+6+4	58+6+4

Options may have reflects on weights and dimensions.



TOOTH K/3
(standard)



TOOTH C/3/SS
(side scraper)



TOOTH BAZ
(side scraper)