

MULTITASKS

MTM

FAE multi-function head for tractors from 220 to 360 hp.

The MTM enables ground stabilization, milling of slabs of rock, crushing of stones, and milling of asphalt, down to a maximum operating depth of 40 cm. The compact size and excellent maneuverability enable the MTM to work on surfaces which are difficult to reach using self-powered vehicles. The variable-geometry crushing chamber guarantees excellent

results in terms of breaking down material. The volume of the chamber increases based on depth with a reduction in fuel consumption and an increase in operating speed. The Hardox® wear-resistant counter blade and grid on the rear hood guarantee the desired granulometry of material processed.



220-360 hp



Depth 40 cm max



Variable displacement chamber

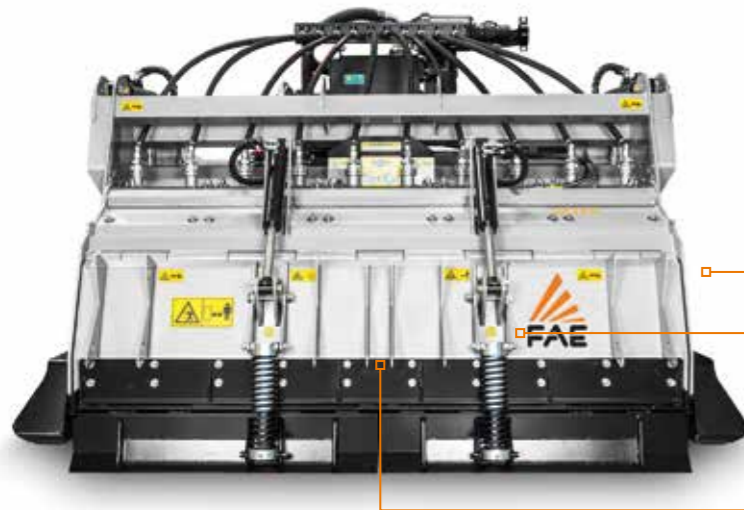

Side wear plates on the inner sides of the frame
highly resistant to wear and tear, equalling less down time due to replacement



Rear access panel

Hardox® steel - Wear plates
these allow the machine to resist wear and tear and can be easily replaced as needed



Rear grid
the grid on the rear door helps define the size of the output materials

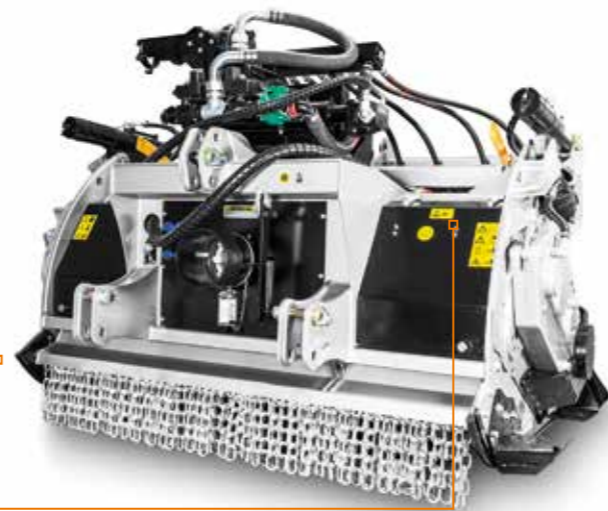

Displacement Chamber

this technological solution, which is one of a kind in the industry, allows the ground to be penetrated with the rotor alone

MAIN OPTIONS



Extended 3 point linkage



Bolt-on chain's protection plates



Multiple tooth options



The **Water Spray System** (High Flow & FCS) has the dual function of cooling and mixing

STANDARD EQUIPMENT

Hydraulic front hood	Gearbox with freewheel
Hydraulic rear hood	PTO shaft (MTM/HP)
Interchangeable inner antiwear plates in Hardox®	Friction clutches
Enclosed machine body	PTO shaft with cam clutch (MTM)
Variable displacement chamber	Bolted-on rotor shafts (in forged steel)
Bolted grid on rear hood	Adjustable Hardox® counter-blade
Inside lateral protection	Adjustable skids
Protection chains	Dozing blades with spring system
Transmission with side gearbox	

OPTIONS

Extended 3 point linkage	Water spray system WSS High Flow
Multiple tooth options	FCS full control system
Hydraulic top link	

MODEL	MTM-200	MTM-225	MTM/HP-200	MTM/HP-225
Tractor (hp)	220-300	220-300	300-360	300-360
PTO (rpm)	1000	1000	1000	1000
Working width (mm)	2053	2293	2053	2293
Total width (mm)	2495	2735	2495	2735
Weight (Kg)	5950	6450	6000	6500
Rotor diameter (mm)	940	940	940	940
ROTOR G/3				
Working depth (mm) (Max. 1-Max. 2)	240-400	240-400	240-400	240-400
No. teeth type G/3+STC/3/FP+STC/FP	94+4+4	106+4+4	94+4+4	106+4+4
Rotor diameter (mm)	915	915	915	915
ROTOR R/65				
Working depth (mm) (Max. 1-Max. 2)	250-400	250-400	250-400	250-400
No. picks/teeth type R/65	158	176	158	176

with rotor only maximum depth (maximum working depth depending on ground conditions). This information refers to the machine equipped as standard. The technical data in this catalogue may be altered without prior notice.

ROTOR TYPE G



TOOTH G/3
(standard)



TOOTH G/3/HD
(option)



ADAPTOR G/3 WITH PICK R/44
(option)



TOOTH STC/FP
(side scraper)



TOOTH STC/3/FP
(side scraper)

ROTOR TYPE R



PICK R/65
(standard)



ADAPTOR R/65 WITH PICK R/44
(option)



PICK R/65/HD
(option)