

FORESTRY MULCHERS FOR EXCAVATORS

UML/HY - UML/HY/VT - UML/HY/SONIC

Forestry mulcher with fixed tooth rotor for excavators.

With its updated design, the UML/HY has increased its strength and durability. The addition of the VT motor option has made the UML/HY/VT one of the most productive units in its class. The hydraulic motor is internally positioned in the frame to protect it

from dirt and potential damage, ensuring maximum reliability throughout the life of the attachment. The VT version with automatic variable displacement hydraulic motor increases productivity by up to 50% and simultaneously reduces fuel consumption.

-  **Sonic System**
-  **90-170 L/min**
-  **Ø 15 cm max**
-  **9-15 t**

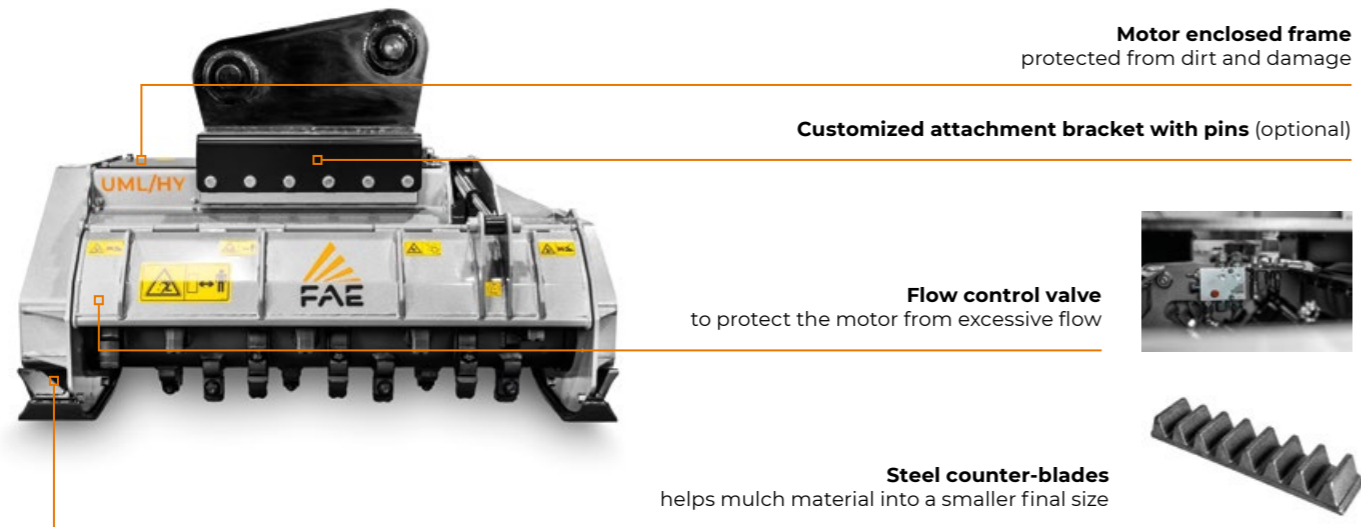

Motor enclosed frame
protected from dirt and damage

Customized attachment bracket with pins (optional)

Flow control valve
to protect the motor from excessive flow

Steel counter-blades
helps mulch material into a smaller final size

Fixed tooth rotor



Sonic System is a new automatic intelligent system that manages the hydraulic transmission. It makes the mulching machine to perform at the maximum capacity in all conditions (UML/HY/SONIC)

80/50cc variable torque hydraulic piston motor
(UML/HY/VT)

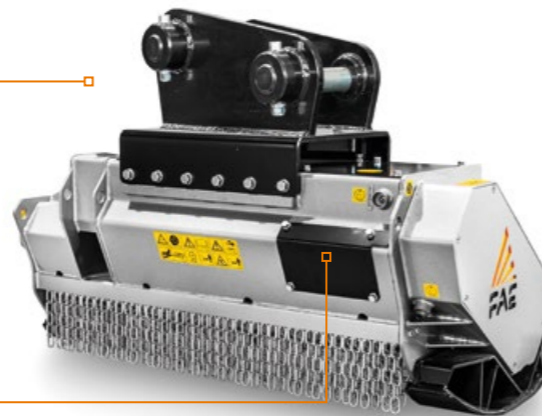

MAIN OPTIONS



Diverter valve
to control the opening and closing of the hydraulic door



Customized attachment bracket with fixed thumb



Bite Limiter rotor
Special steel limiter rings control the depth of blade action (UML/HY/VT)

STANDARD EQUIPMENT

32/65cc variable manual displacement hydraulic piston motor (90-170 L/min) (UML/HY)	80cc variable torque hydraulic piston motor (100-145 L/min) (UML/HY/SONIC)
80/50cc variable torque hydraulic piston motor (100-145 L/min) (UML/HY/VT)	Motor enclosed in the frame
Belt transmission (UML/HY)	Poly Chain® belt transmission (UML/HY/VT - UML/HY/SONIC)
Flow control system valve	Bulkhead for hydraulic connections
Diverter valve (UML/HY/SONIC)	Dual row protection chains
Hydraulic rear hood	Welded counterblades
Safety and anticavitation valve	Sonic System (UML/HY/SONIC)
Enclosed / anti dust machine body	

OPTIONS

Customized setting hydraulic motor (UML/HY - UML/HY/VT)	Customized attachment bracket with pins and leg
Diverter valve (UML/HY - UML/HY/VT)	Multiple tooth options
Rear hood with mechanical adjustment (UML/HY - UML/HY/VT)	Rotor Bite Limiter (UML/HY/VT - UML/HY/SONIC)
Customized attachment bracket with pins	

MODEL	UML/HY 100	UML/HY 125	UML/HY 150	UML/HY/VT 100*	UML/HY/VT 125*	UML/HY/VT 150*	UML/HY/SONIC 100	UML/HY/SONIC 125	UML/HY/SONIC 150
Flow rate (L/min)	90-170	90-170	90-170	90-170	90-170	90-170	90-170	90-170	90-170
Pressure (bar)	180-350	180-350	180-350	180-350	180-350	180-350	180-350	180-350	180-350
Excavator weight (t)	9-15	10-15	11-15	9-15	10-15	11-15	9-15	10-15	11-15
Working width (mm)	1102	1342	1582	1102	1342	1582	1102	1342	1582
Weight (kg)	925	985	1085	940	1000	1100	940	1000	1100
Rotor diameter (mm)	425	425	425	425	425	425	425	425	425
Max shredding diameter (mm)	150	150	150	150	150	150	150	150	150
No. teeth type C/3+C/3/SS	20+2	26+2	32+2	20+2	26+2	32+2	20+2	26+2	32+2
type I+C/3/SS	28+2	36+2	42+2	28+2	36+2	42+2	28+2	36+2	42+2

Data refers to machine as standard. The technical data in this catalogue may be altered without prior notice. *Variable displacement hydraulic motor.

ROTOR TYPE C



ROTOR TYPE I

